

1 Basic characteristics

2 Data Types

Basic characteristics

- Python is a free and open source language, **first written in C**.
- Python is an interpreted language.
- Python is **not** a free-form language.
- Python is a strongly typed language.
- Python is an object-oriented language **but it also supports procedural oriented programming**.

Basic characteristics

- Python is a free and open source language, **first written in C**.
- Python is an interpreted language.
- Python is **not** a free-form language.
- Python is a strongly typed language.
- Python is an object-oriented language **but it also supports procedural oriented programming**.
- Python is a high level language.
- Python is a portable and cross-platform language.

Strings

Substring of a string:

```
str = "malfunctioning" # Indexing starts with 0
print(str[3:6]) # Elements indexed 3 through 5
```

Strings

Substring of a string:

```
str = "malfunctioning" # Indexing starts with 0
print(str[3:6]) # Elements indexed 3 through 5
```

Output:

```
fun
```

Splitting a string:

```
str = "I don't love Python, the snake."
print(str.split(" "), str.split(", "))
```

Strings

Substring of a string:

```
str = "malfunctioning" # Indexing starts with 0
print(str[3:6]) # Elements indexed 3 through 5
```

Output:

```
fun
```

Splitting a string:

```
str = "I don't love Python, the snake."
print(str.split(" "), str.split(", "))
```

Output:

```
['I', "don't", 'love', 'Python,', 'the', 'snake.']
["I don't love Python", 'the snake.']
```

Strings

Negative indexing:

```
str = 'please step on no pets'  
strrev = str[::-1]  
print(strrev)
```

Numbers

Numbers are of three types – int, float, complex.

Examples:

<code>int(1)</code>	<code>1</code>
<code>1.</code>	<code>+3.45e67</code>
<code>float(1)</code>	<code>+3.45e-67</code>
<code>.1</code>	<code>-3.45e-67</code>
<code>1.2345</code>	<code>3.45e67</code>
<code>-0.6789</code>	<code>.00345e-32</code>
<code>+.4560</code>	<code>1e-15</code>
<code>-.1234</code>	<code>1e+15</code>
<code>complex(1,-1)</code>	<code>(1-1j)</code>

Numbers

Numbers are of three types – int, float, complex.

Examples:

<code>int(1)</code>	<code>1</code>
<code>1.</code>	<code>+3.45e67</code>
<code>float(1)</code>	<code>+3.45e-67</code>
<code>.1</code>	<code>-3.45e-67</code>
<code>1.2345</code>	<code>3.45e67</code>
<code>-0.6789</code>	<code>.00345e-32</code>
<code>+.4560</code>	<code>1e-15</code>
<code>-.1234</code>	<code>1e+15</code>
<code>complex(1,-1)</code>	<code>(1-1j)</code>

- Do not use commas as thousand-separators.
- At times behavior may be counter-intuitive.

Numbers

What will be the output of the following?

```
a = 10
```

```
b = 10
```

```
c = 3+7
```

```
d = 11
```

```
e = 12
```

```
print(hex(id(a)), hex(id(b)), hex(id(c)))
```

```
print(hex(id(d)), hex(id(e)))
```

Output:

```
0x7fe59418c210 0x7fe59418c210 0x7fe59418c210
```

```
0x7fe59418c230 0x7fe59418c250
```

Lists – Adding elements

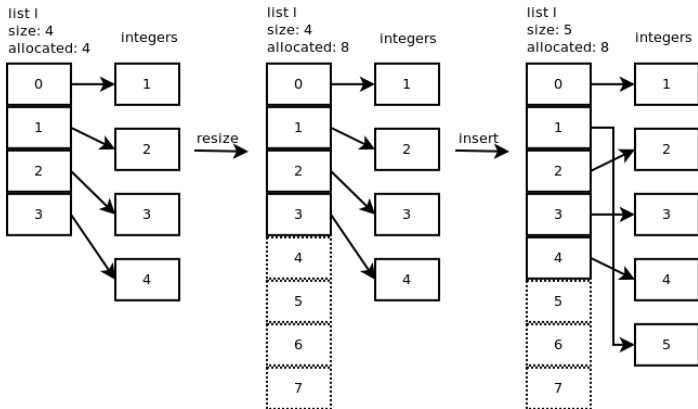

```
ls = []
```

```
ls.append(<data>) # Inserts at the end
```

```
ls.insert(<index>, <data>) # Inserts at the <index>
```

Lists – Adding elements

What will be the output of the following program?

```
ls = [1, 2, 3, 4, 5]
ls.insert(3, 20) # Inserts 20 at index 3
print(ls)
ls.insert(20, 3) # Inserts 3 at index 6 (not at index 20)
print(ls)
```

Lists – Adding elements

What will be the output of the following program?

```
ls = [1, 2, 3, 4, 5]
ls.insert(3, 20) # Inserts 20 at index 3
print(ls)
ls.insert(20, 3) # Inserts 3 at index 6 (not at index 20)
print(ls)
```

Output:

```
[1, 2, 3, 20, 4, 5]
[1, 2, 3, 20, 4, 5, 3]
```

Note: If the list insertion index is out of range then the maximum possible range is taken.

Lists – Adding elements

What will be the output of the following program?

```
ls = [1, 2, 3, 4, 5]
ls[3] = 10 # Assigns 10 at index 3
print(ls)
ls[10] = 3 # Assigns 3 at index 10
print(ls)
```

Lists – Adding elements

What will be the output of the following program?

```
ls = [1, 2, 3, 4, 5]
ls[3] = 10 # Assigns 10 at index 3
print(ls)
ls[10] = 3 # Assigns 3 at index 10
print(ls)
```

Output:

```
[1, 2, 3, 10, 5]
```

Error

Note: List assignment index cannot be out of range.

Lists – Adding multiple elements

```
ls1 = [1, 2, 3, 4]
ls2 = [8, 9, 10, 11]
ls1.extend(ls2) # Extends ls1 by appending ls2
print(ls1)
ls1[4:4] = [5, 6, 7] # Inserts elements from a list
print(ls1)
ls1[4] = [4.5, 5, 5.5] # Inserts a list
print(ls1)
```

Lists – Adding multiple elements

```
ls1 = [1, 2, 3, 4]
ls2 = [8, 9, 10, 11]
ls1.extend(ls2) # Extends ls1 by appending ls2
print(ls1)
ls1[4:4] = [5, 6, 7] # Inserts elements from a list
print(ls1)
ls1[4] = [4.5, 5, 5.5] # Inserts a list
print(ls1)
```

Output:

```
[1, 2, 3, 4, 8, 9, 10, 11]
[1, 2, 3, 4, 5, 6, 7, 8, 9, 10, 11]
[1, 2, 3, 4, [4.5, 5, 5.5], 6, 7, 8, 9, 10, 11]
```

Lists – Adding multiple elements

```
ls1 = [1, 2, 3, 4]
ls2 = [8, 9, 10, 11]
ls1.extend(ls2) # Extends ls1 by appending ls2
print(ls1)
ls1[4:4] = [5, 6, 7] # Inserts elements from a list
print(ls1)
ls1[4] = [4.5, 5, 5.5] # Inserts a list
print(ls1)
```

Output:

```
[1, 2, 3, 4, 8, 9, 10, 11]
[1, 2, 3, 4, 5, 6, 7, 8, 9, 10, 11]
[1, 2, 3, 4, [4.5, 5, 5.5], 6, 7, 8, 9, 10, 11]
```

Note: You may use an iterative control flow.

Lists – Removing elements

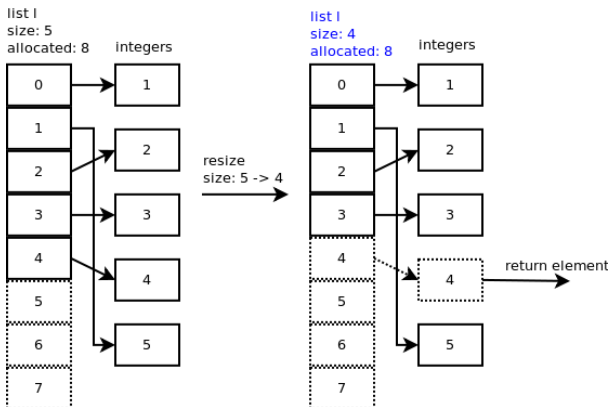

```
ls = []
```

```
<data> = ls.pop() # Deletes from the end
```

```
<data> = ls.pop(<index>) # Deletes from the <index>
```

```
ls.remove(<data>) # Deletes <data>
```

Lists – Removing multiple elements

You may use an iterative control flow.

Lists

Creating list of lists:

```
ls = [[]] * 5  
print(ls)
```

Lists

Creating list of lists:

```
ls = [[]] * 5
print(ls)
```

Output:

```
[[], [], [], [], []]
```

Lists of sublists

What will be the output of the following program?

```
ls1 = [[] for i in range(3)]
ls1[0].append(10)
ls1[1].append(20)
ls1.append(30)
print(ls1)
ls2 = [[]]*3
ls2[0].append(10)
ls2[1].append(20)
ls2.append(30)
print(ls2)
```

Lists of sublists

What will be the output of the following program?

```
ls1 = [[] for i in range(3)]
ls1[0].append(10)
ls1[1].append(20)
ls1.append(30)
print(ls1)
ls2 = [[]]*3
ls2[0].append(10)
ls2[1].append(20)
ls2.append(30)
print(ls2)
```

```
[[10], [20], [], 30]
[[10, 20], [10, 20], [10, 20], 30]
```

Lists

Python Standard Library documentation on the extended list operations can be found at: <https://docs.python.org/3/tutorial/datastructures.html>

Converting Strings to Lists

Strings are just like Lists. One can convert a String into the List by passing the String as an argument to the List as follows.

```
str = "Python 3"  
list(str)
```

Output: ['P', 'y', 't', 'h', 'o', 'n', ' ', '3']

Tuples

Tuples are like lists but immutable in nature, i.e. the elements in the tuple cannot be added or removed once created.

```
tp = ('Language', 'Python')  
print(tp, tp[1])
```

Output: ('Language', 'Python') Python

Tuples

Tuples are like lists but immutable in nature, i.e. the elements in the tuple cannot be added or removed once created.

```
tp = ('Language', 'Python')  
print(tp, tp[1])
```

Output: ('Language', 'Python') Python

Converting lists to tuples:

```
ls = [1, 2, 4, 5, 6]  
Tuple = tuple(list)
```

Tuples

Python Standard Library documentation on the extended tuple operations can be found at: <https://docs.python.org/3/tutorial/datastructures.html>

Dictionary

Creating a Dictionary:

```
dc = {'Course': 'Business Analytics', 1: [28, 29]}  
print("The created dictionary: ", dc)
```

Output:

The created dictionary: 'Course': 'Business Analytics', 1: [28, 29]

Dictionary

Accessing an element from the dictionary:

```
print(dc['Course'], dc[1]) # Accessed by the key  
print(dc.get('Course'), dc.get(1))
```

Output:

```
Business Analytics [28, 29]
```

```
Business Analytics [28, 29]
```

Dictionary

Accessing an element from the dictionary:

```
print(dc['Course'], dc[1]) # Accessed by the key
print(dc.get('Course'), dc.get(1))
```

Output:

```
Business Analytics [28, 29]
Business Analytics [28, 29]
```

Deleting an element from the dictionary:

```
dc.pop('Course')
print("The current dictionary: ", dc)
```

Output:

```
The current dictionary: 1: [28, 29]
```

Dictionary

Python Standard Library documentation on the extended dictionary operations can be found at: <https://docs.python.org/3/tutorial/datastructures.html>

Sets

Sets are (ordered or unordered) collection of data items that is mutable and does not allow any duplicate element.

```
st = {'day', 1, 2, 'for', 'Python', 'Python'}
print(st)
st.add('language')
print(st)
st.remove('for')
print(st)
```

Output:

```
{'Python', 1, 2, 'for', 'day'}
{'Python', 1, 2, 'for', 'day', 'language'}
{'Python', 1, 2, 'day', 'language'}
```

Note: Sets are not subscriptable.

Sets

Python Standard Library documentation on the extended set operations can be found at: <https://docs.python.org/3/tutorial/datastructures.html>

Boolean values

Any non-zero value is treated as True and zero is treated as False.

Examples:

0	False	0e10	False
1	True	'A'	True
6 - 2 * 3	False	"A"	True
(6 - 2) * 3	True	'\0'	True
0.0075	True	(0, 0)	True
"	False	""	False

Boolean values

Any non-zero value is treated as True and zero is treated as False.

Examples:

0	False	0e10	False
1	True	'A'	True
6 - 2 * 3	False	"A"	True
(6 - 2) * 3	True	'\0'	True
0.0075	True	(0, 0)	True
"	False	""	False

Note: The expressions like "x = 0" or "x = 1" will exhibit error.

Mutable and immutable objects

Everything in Python is an object and it is either mutable or immutable.

A mutable object can be changed to a different type after it is created, but an immutable object cannot be changed.

- Objects of built-in types like int, float, bool, str, tuple, unicode are immutable.
- Objects of built-in types like list, set, dict are mutable.

Verifying the data type

```
type(3)
```

Output: int

```
type(3.14)
```

Output: float

Verifying the data type

```
type(3)
```

Output: int

```
type(3.14)
```

Output: float

```
type('pi')
```

Output: str

```
type([3.14, 3.142, 3.1428])
```

Output: list

```
type(True)
```

Output: bool